

Dialogannahme

ШИНОМОНТАЖНЫЕ СТАНКИ

КАТАЛОГ

Архангельск (8182)63-90-72
Астана (7172)727-132
Астрахань (8512)99-46-04
Барнаул (3852)73-04-60
Белгород (4722)40-23-64
Брянск (4832)59-03-52
Владивосток (423)249-28-31
Волгоград (844)278-03-48
Вологда (8172)26-41-59
Воронеж (473)204-51-73
Екатеринбург (343)384-55-89
Иваново (4932)77-34-06

Ижевск (3412)26-03-58
Иркутск (395)279-98-46
Казань (843)206-01-48
Калининград (4012)72-03-81
Калуга (4842)92-23-67
Кемерово (3842)65-04-62
Киров (8332)68-02-04
Краснодар (861)203-40-90
Красноярск (391)204-63-61
Курск (4712)77-13-04
Липецк (4742)52-20-81

Киргизия (996)312-96-26-47

Магнитогорск (3519)55-03-13
Москва (495)268-04-70
Мурманск (8152)59-64-93
Набережные Челны (8552)20-53-41
Нижний Новгород (831)429-08-12
Новокузнецк (3843)20-46-81
Новосибирск (383)227-86-73
Омск (3812)21-46-40
Орел (4862)44-53-42
Оренбург (3532)37-68-04
Пенза (8412)22-31-16

Россия (495)268-04-70

Пермь (342)205-81-47
Ростов-на-Дону (863)308-18-15
Рязань (4912)46-61-64
Самара (846)206-03-16
Санкт-Петербург (812)309-46-40
Саратов (845)249-38-78
Севастополь (8692)22-31-93
Симферополь (3652)67-13-56
Смоленск (4812)29-41-54
Сочи (862)225-72-31
Ставрополь (8652)20-65-13

Казахстан (772)734-952-31

Сургут (3462)77-98-35
Тверь (4822)63-31-35
Томск (3822)98-41-53
Тула (4872)74-02-29
Тюмень (3452)66-21-18
Ульяновск (8422)24-23-59
Уфа (347)229-48-12
Хабаровск (4212)92-98-04
Челябинск (351)202-03-61
Череповец (8202)49-02-64
Ярославль (4852)69-52-93

<https://beissbarth.nt-rt.ru> || bhp@nt-rt.ru

Passenger car tyre changer Start Line TF 311 | 400/3/50 | RAL7016

The entry solution: efficient, fast, good | 9-20" outside rim diameter | 1 Speed

Article number: 1 694 400 024



Perfect for workshops with low to medium volume. Quick and efficient.

- Easy tilt-back pole
- Self-centering four-jaw turntable for precising clamping of the wheel
- Plastic protection on the mounting tool for safe clamping of alloy wheels
- Easy and quick use of pedals - Tilting of mounting arm - Opening and closing jaws of turntable - Control of bead breaker arm - Turning of turntable
- Integrated bead breaker with smooth movement
- Mechanical lock of mounting tool

Optional: For changing runflat tyres (RFT) the TF311 can be extended by an assistance arm (1695903411)

Scope of delivery:

- Inflation gun with pressure gauge
- Mounting tool

Color: RAL7016

Passenger car tyre changer Start Line TF 311 | 230/1/50 | RAL7016

The entry solution: efficient, fast, good | 9-20" outside rim diameter | 1 Speed

Article number: 1 694 400 025



Perfect for workshops with low to medium volume. Quick and efficient.

- Easy tilt-back pole
- Self-centering four-jaw turntable for precising clamping of the wheel
- Plastic protection on the mounting tool for safe clamping of alloy wheels
- Easy and quick use of pedals - Tilting of mounting arm - Opening and closing jaws of turntable - Control of bead breaker arm - Turning of turntable
- Integrated bead breaker with smooth movement
- Mechanical lock of mounting tool

Optional: For changing runflat tyres (RFT) the TF311 can be extended by an assistance arm (1695903411)

Scope of delivery:

- Inflation gun with pressure gauge
- Mounting tool

Color: RAL7016

Passenger car tyre changer Start Line TF 311 | 230/1/60 | RAL7016

The entry solution: efficient, fast, good | 9-20" outside rim diameter | 1 Speed

Article number: 1 694 400 027



Perfect for workshops with low to medium volume. Quick and efficient.

- Easy tilt-back pole
- Self-centering four-jaw turntable for precising clamping of the wheel
- Plastic protection on the mounting tool for safe clamping of alloy wheels
- Easy and quick use of pedals - Tilting of mounting arm - Opening and closing jaws of turntable - Control of bead breaker arm - Turning of turntable
- Integrated bead breaker with smooth movement
- Mechanical lock of mounting tool

Optional: For changing runflat tyres (RFT) the TF311 can be extended by an assistance arm (1695903411)

Scope of delivery:

- Inflation gun with pressure gauge
- Mounting tool

Color: RAL7016

Passenger car tyre changer Start Line TF 311 | 400/3/50 | RAL5015

The entry solution: efficient, fast, good | 9-20" outside rim diameter | 1 Speed

Article number: 1 694 200 947



Perfect for workshops with low to medium volume. Quick and efficient.

- Easy tilt-back pole
- Self-centering four-jaw turntable for precising clamping of the wheel
- Plastic protection on the mounting tool for safe clamping of alloy wheels
- Easy and quick use of pedals - Tilting of mounting arm - Opening and closing jaws of turntable - Control of bead breaker arm - Turning of turntable
- Integrated bead breaker with smooth movement
- Mechanical lock of mounting tool

Optional: For changing runflat tyres (RFT) the TF311 can be extended by an assistance arm (1695903411)

Scope of delivery:

- Inflation gun with pressure gauge
- Mounting tool

Color: RAL5015

Passenger car tyre changer MS 530 S | RAL5015

Pneumatic passenger car tyre changer, specially developed for intensive use | Clamping range 10 - 22"

Article number: 1 694 201 113



The NEW "S" concept:

- Robust mechanism with welded bead breaker
- Extended working area between tyre and mounting head
- Space saving: 50 mm smaller than comparable machines
- Service-friendly: removable pedal system for easy maintenance
- Flexibly upgradeable with a wheel lift for even better ergonomics
- Double rotation speed (7.5 - 13 rpm)
- Automatic wheel release vertical and horizontal

Optionally available as an accessory:

- Side Lift NG
- Tubeless Inflation Kit

Scope of delivery:

- MS 530 S
- Individually adjustable tyre paste holder
- Bead depressor plate, mounting lever

Color: RAL5015

Passenger car tyre changer MS 530 S | RAL7040

Pneumatic passenger car tyre changer, specially developed for intensive use | Clamping range 10 - 22"

Article number: 1 694 201 114



The NEW "S" concept:

- Robust mechanism with welded bead breaker
- Extended working area between tyre and mounting head
- Space saving: 50 mm smaller than comparable machines
- Service-friendly: removable pedal system for easy maintenance
- Flexibly upgradeable with a wheel lift for even better ergonomics
- Double rotation speed (7.5 - 13 rpm)
- Automatic wheel release vertical and horizontal

Optionally available as an accessory:

- Side Lift NG
- Tubeless Inflation Kit

Scope of delivery:

- MS 530 S
- Individually adjustable tyre paste holder
- Bead depressor plate, mounting lever
- Plastic protection for bead breaker
- Plastic protection for mounting head

Color: RAL7040

Passenger car tyre changer MS 530 S IT | RAL5015

Pneumatic passenger car tyre changer, specially developed for intensive use | Clamping range 10 - 22" | integrated inflation technology

Article number: 1 694 201 115



The NEW "S" concept:

- Robust mechanism with welded bead breaker
- Extended working area between tyre and mounting head
- Space saving: 50 mm smaller than comparable machines
- Service-friendly: removable pedal system for easy maintenance
- Flexibly upgradeable with a wheel lift for even better ergonomics
- Double rotation speed (7.5 - 13 rpm)
- Automatic wheel release vertical and horizontal

Optionally available as an accessory:

- Side Lift NG

Scope of delivery:

- MS 530 S IT
- Individually adjustable tyre paste holder
- Bead depressor plate, mounting lever
- Plastic protection for bead breaker
- Plastic protection for mounting head
- Tubeless Inflation Kit (IT)

Color: RAL5015

Passenger car tyre changer MS 530 S IT | RAL7040

Pneumatic passenger car tyre changer, specially developed for intensive use | Clamping range 10 - 22" | integrated inflation technology

Article number: 1 694 201 116



The NEW "S" concept:

- Robust mechanism with welded bead breaker
- Extended working area between tyre and mounting head
- Space saving: 50 mm smaller than comparable machines
- Service-friendly: removable pedal system for easy maintenance
- Flexibly upgradeable with a wheel lift for even better ergonomics
- Double rotation speed (7.5 - 13 rpm)
- Automatic wheel release vertical and horizontal

Optionally available as an accessory:

- Side Lift NG

Scope of delivery:

- MS 530 S IT
- Individually adjustable tyre paste holder
- Bead depressor plate, mounting lever
- Plastic protection for bead breaker
- Plastic protection for mounting head
- Tubeless Inflation Kit (IT)

Color: RAL7040

Passenger car tyre changer MS 530 S V1 WDK

Pneumatic passenger car tyre changer, specially developed for intensive use | Clamping range 10 - 22" | incl. assistance column Tecnoroller NG

Article number: 1 694 201 118



- Together with the assistance column Tecnoroller NG they have a safe and easy assembly and disassembly procedure, also for UHP and run flat tyres.

The NEW "S" concept:

- Robust mechanism with welded bead breaker
- Extended working area between tyre and mounting head
- Space saving: 50 mm smaller than comparable machines
- Service-friendly: removable pedal system for easy maintenance
- Flexibly upgradeable with a wheel lift for even better ergonomics
- Pre-assembled Tecnoroller NG assistance column with separately controllable auxiliary arms
- Double rotation speed (7.5 - 13 rpm)
- Automatic wheel release vertical and horizontal

Optionally available as an accessory:

- Side Lift NG
- Inflation Tubeless Kit

Scope of delivery:

- MS 530 S V1 WDK with pre-assembled Tecnoroller NG assistance column
- wdk kit
- Individually adjustable tyre paste holder
- Bead depressor plate, mounting lever
- Plastic protection for bead breaker
- Plastic protection for mounting head

Truck tyre changer MS 70

Universal fitting technology up to 26" rim diameter | up to a wheel width of 800 mm | adjustable hydraulic pressure and clamping force

Article number: 1 694 200 070



- The technical design of the MS 70 allows easy fitting of all tyres to a maximum wheel width of 800 mm.
- The bi-directional robust wheel clamping device ensures a high degree of safety when fitting and dismantling wheel assemblies.
- The hydraulic pressure arm maintains exceptional movement during the process. These are features of Beissbarth products which universally acclaimed as innovative as well as practical.

Sturdy jaw clamp

- Each wheel is firmly held by four clamping jaws. The clamping jaws allows bi-direction of the device for easy removal and fitting of tyres. These features bring reliability and robustness as part of the Beissbarth approach to technology.

Practical details

- The pressure roller can be turned to two positions and locked. This makes breaking of tyre beads easier. The fitting hook is used for wheels with tubes or commercial vehicles.

Truck tyre changer MS 75

Tyre Fitting for all commercial and agricultural vehicles | Rim diameter 14 - 42", with clamp extension until 56" | up to a wheel width of 910 mm | adjustable hydraulic pressure | two rotational speeds

Article number: 1 694 200 074



- MS 75 - first choice for tyres on trucks, buses and agricultural vehicles up to a wheel width of 910 mm.
- The adjustable hydraulic pressure ensures safe fitting/dismantling of alloy wheel assemblies.
- The large fitting carriage and the maximum pressure force of 3.7 t enable work on super-singles and heavy commercial vehicle wheels.
- The 4-jaw clamping unit can be rotated in either direction with the choice of two speeds.
- All of these factors make the MS 75 the ideal universal fitting device for your company.

Portable control unit

- The mobile low-voltage control panel enables singlehanded operation of the tyre changer. Your ability to observe the operation is not compromised where safety is concerned.

Sturdy jaw clamp

- Each wheel is firmly held by four clamping jaws. The twin speed rotation of the clamping device makes fitting and dismantling much easier.

Truck tyre changer MS 78

Safe tyre fitting for commercial vehicles | Rim diameter 14 - 42", with clamp extension until 56" | 6-point jaw clamp | Easy to use - with joystick

Article number: 1 694 200 079



- Repair workshops that work principally with big commercial vehicles and agricultural machinery take up the MS 78 for the tyre-fitting service.
- Not just because the robust design guarantees that it can be used safely. But mainly due to its outstanding fitting technology and its ease of use - operators manipulate a joystick on the portable operating console, optionally with remote control.
- No need to send customers away because you cannot handle their tyres - not even customers operating tractors, or timber skidders, for example.
- Because the MS 78 means fitting technology for every size.

Joystick or radio control

- The MS 78 comes as standard with a mobile operating console with joystick. This ensures that the machine is easy and safe to use from any position. Wireless version as option.

6-point jaw clamp

- This is a crucial feature of perfect grip. Clamping jaws hold each wheel firmly at six points. So rims cannot slip while you are fitting the tyre.

Protection for aluminium rims

- Clamping jaws can grab gently - when necessary - with sensitive joystick operation and plastic fixings (extra option) in the clamping jaws.

Truck tyre changer MS 78 RC

Safe tyre fitting for commercial vehicles | Rim diameter 14 - 42", with clamp extension until 56" | 6-point jaw clamp | Easy to use - with radio control

Article number: 1 694 200 081



- Repair workshops that work principally with big commercial vehicles and agricultural machinery take up the MS 78 RC for the tyre-fitting service.
- Not just because the robust design guarantees that it can be used safely. But mainly due to its outstanding fitting technology and its ease of use - operators manipulate with remote control.
- No need to send customers away because you cannot handle their tyres - not even customers operating tractors, or timber skidders, for example.
- Because the MS 78 RC means fitting technology for every size.

Wireless control

- The MS 78 RC comes with a remote control. This ensures that the machine is easy and safe to use from any position.

6-point jaw clamp

- This is a crucial feature of perfect grip. Clamping jaws hold each wheel firmly at six points. So rims cannot slip while you are fitting the tyre.

Protection for aluminium rims

- Clamping jaws can grab gently - when necessary - with sensitive joystick operation and plastic fixings (extra option) in the clamping jaws.

Also available as a version with mobile operating console with joystick (item no. 1 694 200 079).

Truck tyre changer MS 80

Superlative tyre changing - A new dimension in quality and strength | Rim diameter 14 - 60" (with clamp extension) | up to a wheel width of 1550 mm

Article number: 1 694 200 083



Beissbarth's largest tyre changer isn't outpaced by anything. It can easily change tyres of up to 3 metres in diameter on wheels weighing up to 2.8 tons - all at the touch of a button. Thanks to its large clamping range, the MS 80 can also handle light trucks, heavy duty trucks, agricultural vehicles and trailers.

All functions are hydraulic and controlled using the joysticks on the operating unit, with a bead breaker force of over 4 tons.

Under control

- A lot helps a lot. Large and heavy wheels are held safely in place with the patented 6-clamp coupling and no longer move - even during extremely difficult mountings
- Chuck with bi-directional rotation function

Gentle giant

- If needs be, the MS 80 can also grip very gently - thanks to its regulated hydraulic pressure and plastic clamps (available as accessories).
- Adjustable hydraulic pressure for light wheels

Quick Tool Setup

- High performing pivoting tool with bead breaker disc and mounting/demounting hook
- Quick tool set-up fully controlled through the remote control with tangency positioning (patented)

Color: RAL5015

Inflation Cage | for truck tyres

Safe inflation of truck tyres of up to 1500mm in diameter

Article number: 1 694 302 032

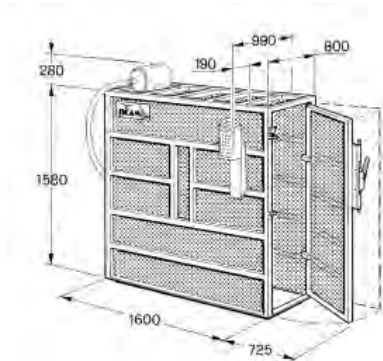

Safety First!

Protects user during inflation of industrial tyres with a diameter of up to 1500mm.

The special type of perforated mesh enclosing the structure minimizes the shock wave which might be generated by a tyre burst.

Note: Tubeless inflation kit and the electronic inflation control need to be ordered separately.

Passenger car tyre changer MS 670 S V6

For premium service | Rim diameter inches 13 - 30" | Standard mounting/demounting tool | incl. assistance column Tecnoroller NG, bead breaker and single-lever central voltage

Article number: 1 694 201 295



- Traditional machine design for quick training coupled with all the features and comfort for a safe and effortless tyre change.
- The Ergo Control bead breaker, which is easy to operate with one hand, and the Side Lift NG always allow you to work in an ergonomic and safe position.
- Special electronics automatically provide higher torque and smooth start-up. Tecnoroller NG assistance column with separately controllable auxiliary arms
- Ergo Control bead breaker - without pedal, only fine and powerful controllable by hand, recoilless Mounting column in "oversized" design (140 x 140 mm)
- Ultra-quick wheel clamping system Adjustable tyre paste holder
- Automatic wheel release vertical and horizontal

Scope of delivery:

- Passenger car tyre changer MS 670 S V6
- Assistance pillar Tecnoroller 2 NG with double horizontal arm, for even more support
- Ergo Control bead breaker
- Side Lift NG, directly at the bead breaker
- Plastic protection for mounting head
- Plastic protection for bead breaker
- Bead depressor plate
- Central locking Protection
- Cone protection central voltage
- Bolt protection central voltage
- Cone Ø 70 mm
- Storage ring for horizontal arm

Passenger car tyre changer MS 670 S V8

For premium service | Rim diameter inches 13 - 30" | Leverless mounting/demounting tool | incl. assistance column Tecnoroller NG, bead breaker, single-lever central voltage, side storage and Side Lift NG

Article number: 1 694 201 271



- Traditional machine design for quick training coupled with all the features and comfort for a safe and effortless tyre change.
- The Ergo Control bead breaker, which is easy to operate with one hand, and the Side Lift NG always allow you to work in an ergonomic and safe position.
- Special electronics automatically provide higher torque and smooth start-up.
- In addition, the leverless assembly head TLL enables a simple, fast and controlled process, even when used with UHP / run flat tyres.
- Tecnoroller NG assistance column with separately controllable auxiliary arms
- Ergo Control bead breaker - without pedal, only fine and powerful controllable by hand, recoilless
- Mounting column in "oversized" design (140 x 140 mm)
- Ultra-quick wheel clamping system
- Adjustable tyre paste holder
- Automatic wheel release vertical and horizontal

Scope of delivery:

- Passenger car tyre changer MS 670 S V8
- Assistance pillar Tecnoroller NG with double horizontal arm, for even more support
- Ergo Control bead breaker
- Side Lift NG, directly at the bead breaker
- Tyre filling system
- Plastic protection for mounting head
- Plastic protection for bead breaker
- Bead depressor plate
- Central locking Protection
- Cone protection central voltage
- Bolt protection central voltage
- Cone Ø 70 mm
- Storage ring for horizontal arm

Passenger car tyre changer MS 670 S V8 IT

For premium service | Rim diameter inches 13 - 30" | Leverless mounting/demounting tool | incl. assistance column Tecnoroller NG, bead breaker, single-lever central voltage, side storage and Side Lift NG | integrated Inflation Technology

Article number: 1 694 201 272



- Traditional machine design for quick training coupled with all the features and comfort for a safe and effortless tyre change.
- The Ergo Control bead breaker, which is easy to operate with one hand, and the Side Lift NG always allow you to work in an ergonomic and safe position.
- Special electronics automatically provide higher torque and smooth start-up.
- In addition, the leverless assembly head TLL enables a simple, fast and controlled process, even when used with UHP / run flat tyres.
- Tecnoroller NG assistance column with separately controllable auxiliary arms
- Ergo Control bead breaker - without pedal, only fine and powerful controllable by hand, recoilless
- Mounting column in "oversized" design (140 x 140 mm)
- Ultra-quick wheel clamping system
- Adjustable tyre paste holder
- Automatic wheel release vertical and horizontal

Scope of delivery:

- Passenger car tyre changer MS 670 S V8 IT
- With integrated Inflation Technology (IT)
- Assistance pillar Tecnoroller NG with double horizontal arm, for even more support
- Ergo Control bead breaker
- Side Lift NG, directly at the bead breaker
- Tyre filling system
- Plastic protection for mounting head
- Plastic protection for bead breaker
- Bead depressor plate
- Central locking Protection
- Cone protection central voltage
- Bolt protection central voltage
- Cone Ø 70 mm
- Storage ring for horizontal arm

Passenger car tyre changer MS 800

For premium service | Rim diameter 13-32" | Ultimate tyre protection with the patented SafeMount tool | Center clamp | Integrated wheel lift

Article number: 1 694 201 466



If tyres could choose: MS800

- SafeMount: extremely tire-friendly de-mounting without rim contact (patented)
- Fast and reliable assembly of UHP and RFT tires without lever
- Dual-synchronized bead breaker discs remove even the toughest tires easily and efficiently from the rim
- Quick and safe clamping with central clamping flange and quick-release system
- Compact design and positioning of the auxiliary arms
- Integrated wheel lift reduces strain on the back
- Full control of the wheel rotation with the two speed pedal system

Scope of delivery:

- MS800
- Brush
- Plastic de-mounting lever
- Quick release nut
- Central locking pin
- Quick mounting clamp
- Bead presser
- Plastic protection for mounting tool
- Plastic protection for centering cone
- Centering cone 41-118mm with ring
- Lever protection for wheel lift

Passenger car tyre changer MS 800 | WDK

For premium service | Rim diameter 13-32" | Ultimate tyre protection with the patented SafeMount tool | Center clamp | Integrated wheel lift | WDK

Article number: 1 694 201 456



If tyres could choose: MS800

- SafeMount: extremely tire-friendly de-mounting without rim contact (patented)
- Fast and reliable assembly of UHP and RFT tires without lever
- Dual-synchronized bead breaker discs remove even the toughest tires easily and efficiently from the rim
- Quick and safe clamping with central clamping flange and quick-release system
- Compact design and positioning of the auxiliary arms
- Integrated wheel lift reduces strain on the back
- Full control of the wheel rotation with the two speed pedal system

Scope of delivery:

- MS800
- Brush
- Plastic de-mounting lever
- Quick release nut
- Central locking pin
- Quick mounting clamp
- Bead presser
- Plastic protection for mounting tool
- Plastic protection for centering cone
- Centering cone 41-118mm with ring
- Lever protection for wheel lift
- WDK certified with WDK accessories

Passenger car tyre changer MS 630 S V6 WDK

The new S class of tyre mounting: strength, robustness and stability | Clamping range 10 - 24" | incl. assistance column Tecnoroller NG | Two speeds | Soft start

Article number: 1 694 201 235



- Full control over the assembly and disassembly procedure with the assistance column: For the protection of tyre, rim and tyre pressure monitoring system.

The NEW "S" concept:

- Robust mechanism with welded bead breaker
- Extended working area between tyre and mounting head
- Space saving: 50 mm smaller than comparable machines
- Service-friendly: removable pedal system for easy maintenance
- Flexibly upgradeable with a wheel lift for even better ergonomics
- Tecnoroller NG assistance column with separately controllable auxiliary arms
- Ergo Control bead breaker - without pedal, only fine and powerful controllable by hand, recoilless
- Mounting column in "oversized" design (140 x 140 mm)
- Internal clamping for steel rims without removal of the plastic protection
- Self-centering four-jaw chuck
- Adjustable tyre paste holder
- Automatic wheel release vertical and horizontal

Scope of delivery:

- MS 630 S V6 230/1/50 WDK
- Assistant column Tecnoroller NG
- Ergo Control bead breaker
- Plastic protection for mounting head
- Plastic protection for bead breaker
- Bead hold-down plate
- Position marker for horizontal arm

Passenger car tyre changer MS 630 S V6 230/1/50 | with inverter

The new S class of tyre mounting: strength, robustness and stability | Clamping range 10 - 24" | incl. assistance column Tecnoroller NG and soft start

Article number: 1 694 201 234



- Together with the assistance column and soft start, full control over the assembly and disassembly procedure: For the protection of tyre, rim and tyre pressure monitoring system.

The NEW "S" concept:

- Robust mechanism with welded bead breaker
- Extended working area between tyre and mounting head
- Space saving: 50 mm smaller than comparable machines
- Service-friendly: removable pedal system for easy maintenance
- Flexibly upgradeable with a wheel lift for even better ergonomics
- Tecnoroller NG assistance column with separately controllable auxiliary arms
- Ergo Control bead breaker - without pedal, only fine and powerful controllable by hand, recoil-less
- Mounting column in "oversized" design (140 x 140 mm)
- Internal clamping for steel rims without removal of the plastic protection
- Self-centering four-jaw chuck
- Adjustable tyre paste holder
- Automatic wheel release vertical and horizontal

Scope of delivery:

- MS 630 S V6 230/1/50
- Assistant column Tecnoroller NG
- Ergo Control bead breaker
- Side Wheel Lift NG
- Plastic protection for mounting head
- Plastic protection for bead breaker
- Bead hold-down plate
- Position marker for horizontal arm

Color: RAL7040

Passenger car tyre changer MS 630 S 400/3/50

The new S class of tyre mounting: strength, robustness and stability | Clamping range 10 - 24"

Article number: 1 694 201 158



The NEW "S" concept:

- Robust mechanism with welded bead breaker
- Extended working area between tyre and mounting head
- Space saving: 50 mm smaller than comparable machines
- Service-friendly: removable pedal system for easy maintenance
- Flexibly upgradeable with a wheel lift for even better ergonomics
- Mounting column in "oversized" design (140 x 140 mm)
- Internal clamping for steel rims without removal of the plastic protection
- Self-centering four-jaw chuck
- Adjustable tyre paste holder
- Automatic wheel release vertical and horizontal

Scope of delivery:

- MS 630 S 400/3/50
- Plastic protection for mounting head
- Plastic protection for bead breaker
- Bead hold-down plate
- Position marker for horizontal arm

Color: RAL5015

Passenger car tyre changer MS 630 S V1 400/3/50 | incl. assistance column Tecnoroller NG

The new S class of tyre mounting: strength, robustness and stability | Clamping range 10 - 24"

Article number: 1 694 201 160



The NEW "S" concept:

- Robust mechanism with welded bead breaker
- Extended working area between tyre and mounting head
- Space saving: 50 mm smaller than comparable machines
- Service-friendly: removable pedal system for easy maintenance
- Flexibly upgradeable with a wheel lift for even better ergonomics
- Tecnoroller NG assistance column with separately controllable auxiliary arms
- Mounting column in "oversized" design (140 x 140 mm)
- Internal clamping for steel rims without removal of the plastic protection
- Self-centering four-jaw chuck
- Adjustable tyre paste holder
- Automatic wheel release vertical and horizontal

Scope of delivery:

- MS 630 S V1 400/3/50
- Assistance column Tecnoroller NG
- Plastic protection for mounting head
- Plastic protection for bead breaker
- Bead hold-down plate
- Position marker for horizontal arm

Color: RAL5015

Passenger car tyre changer MS 630 S V6 400/3/50 | Two speeds

The new S class of tyre mounting: strength, robustness and stability | Clamping range 10 - 24" | incl. assistance column Tecnoroller NG | Two speeds

Article number: 1 694 201 162



- Full control over the assembly and disassembly procedure with the assistance column: For the protection of tyre, rim and tyre pressure monitoring system.

The NEW "S" concept:

- Robust mechanism with welded bead breaker
- Extended working area between tyre and mounting head
- Space saving: 50 mm smaller than comparable machines
- Service-friendly: removable pedal system for easy maintenance
- Flexibly upgradeable with a wheel lift for even better ergonomics
- Tecnoroller NG assistance column with separately controllable auxiliary arms
- Ergo Control bead breaker - without pedal, only fine and powerful controllable by hand, recoil-less
- Mounting column in "oversized" design (140 x 140 mm)
- Internal clamping for steel rims without removal of the plastic protection
- Self-centering four-jaw chuck
- Adjustable tyre paste holder
- Automatic wheel release vertical and horizontal

Scope of delivery:

- MS 630 S V6 400/3/50
- Assistant column Tecnoroller NG
- Ergo Control bead breaker
- Plastic protection for mounting head
- Plastic protection for bead breaker
- Bead hold-down plate
- Position marker for horizontal arm

Color: RAL5015

Passenger car tyre changer MS 630 S 400/3/50 | RAL7040

The new S class of tyre mounting: strength, robustness and stability | Clamping range 10 - 24"

Article number: 1 694 201 217



The NEW "S" concept:

- Robust mechanism with welded bead breaker
- Extended working area between tyre and mounting head
- Space saving: 50 mm smaller than comparable machines
- Service-friendly: removable pedal system for easy maintenance
- Flexibly upgradeable with a wheel lift for even better ergonomics
- Mounting column in "oversized" design (140 x 140 mm)
- Internal clamping for steel rims without removal of the plastic protection
- Self-centering four-jaw chuck
- Adjustable tyre paste holder
- Automatic wheel release vertical and horizontal

Scope of delivery:

- MS 630 S 400/3/50
- Plastic protection for mounting head
- Plastic protection for bead breaker
- Bead hold-down plate
- Position marker for horizontal arm

Color: RAL7040

Passenger car tyre changer MS 630 S V1 400/3/50 | incl. assistance column Tecnoroller NG | RAL7040

The new S class of tyre mounting: strength, robustness and stability | Clamping range 10 - 24"

Article number: 1 694 201 219



- Full control over the assembly and disassembly procedure with the assistance column: For the protection of tyre, rim and tyre pressure monitoring system.

The NEW "S" concept:

- Robust mechanism with welded bead breaker
- Extended working area between tyre and mounting head
- Space saving: 50 mm smaller than comparable machines
- Service-friendly: removable pedal system for easy maintenance
- Flexibly upgradeable with a wheel lift for even better ergonomics
- Tecnoroller NG assistance column with separately controllable auxiliary arms
- Mounting column in "oversized" design (140 x 140 mm)
- Internal clamping for steel rims without removal of the plastic protection
- Self-centering four-jaw chuck
- Adjustable tyre paste holder
- Automatic wheel release vertical and horizontal

Scope of delivery:

- MS 630 S V1 400/3/50
- Assistance column Tecnoroller NG
- Plastic protection for mounting head
- Plastic protection for bead breaker
- Bead hold-down plate
- Position marker for horizontal arm

Color: RAL7040

Passenger car tyre changer MS 630 S V6 400/3/50 | Two speeds | RAL7040

The new S class of tyre mounting: strength, robustness and stability | Clamping range 10 - 24" | incl. assistance column Tecnoroller NG | Two speeds

Article number: 1 694 201 221



- Full control over the assembly and disassembly procedure with the assistance column: For the protection of tyre, rim and tyre pressure monitoring system.

The NEW "S" concept:

- Robust mechanism with welded bead breaker
- Extended working area between tyre and mounting head
- Space saving: 50 mm smaller than comparable machines
- Service-friendly: removable pedal system for easy maintenance
- Flexibly upgradeable with a wheel lift for even better ergonomics
- Tecnoroller NG assistance column with separately controllable auxiliary arms
- Ergo Control bead breaker - without pedal, only fine and powerful controllable by hand, recoil-less
- Mounting column in "oversized" design (140 x 140 mm)
- Internal clamping for steel rims without removal of the plastic protection
- Self-centering four-jaw chuck
- Adjustable tyre paste holder
- Automatic wheel release vertical and horizontal

Scope of delivery:

- MS 630 S V6 400/3/50
- Assistant column Tecnoroller NG
- Ergo Control bead breaker
- Plastic protection for mounting head
- Plastic protection for bead breaker
- Bead hold-down plate
- Position marker for horizontal arm

Color: RAL7040

Passenger car tyre changer MS 630 S V6 | WDK | 400/3/50 | RAL7040

The new S class of tyre mounting: strength, robustness and stability | Clamping range 10 - 24" | incl. assistance column Tecnoroller NG | Two speeds
Article number: 1 694 201 222



- Full control over the assembly and disassembly procedure with the assistance column: For the protection of tyre, rim and tyre pressure monitoring system.

The NEW "S" concept:

- Robust mechanism with welded bead breaker
- Extended working area between tyre and mounting head
- Space saving: 50 mm smaller than comparable machines
- Service-friendly: removable pedal system for easy maintenance
- Flexibly upgradeable with a wheel lift for even better ergonomics
- Tecnoroller NG assistance column with separately controllable auxiliary arms
- Ergo Control bead breaker - without pedal, only fine and powerful controllable by hand, recoilless
- Mounting column in "oversized" design (140 x 140 mm)
- Internal clamping for steel rims without removal of the plastic protection
- Self-centering four-jaw chuck
- Adjustable tyre paste holder
- Automatic wheel release vertical and horizontal

Scope of delivery:

- MS 630 S V6 WDK 400/3/50
- Assistant column Tecnoroller NG
- Ergo Control
- Side Wheel Lift NG
- Plastic protection for mounting head
- Plastic protection for bead breaker
- Bead hold-down plate
- Position marker for horizontal arm

Color: RAL7040

Passenger car tyre changer MS 650 S V1 | RAL7040 | WDK

The new S class of tyre mounting: strength, robustness and stability | Clamping range 12 - 28" | incl. assistance column Tecnoroller NG | without Tyre Leverless System

Article number: 1 694 201 254



- Take full control over the assembly and disassembly procedure: For the protection of tyre, rim and tyre pressure monitoring system.

The NEW "S" concept:

- Robust mechanism with welded bead breaker
- Extended working area between tyre and mounting head
- Space saving: 50 mm smaller than comparable machines
- Service-friendly: removable pedal system for easy maintenance
- Flexibly upgradeable with a wheel lift for even better ergonomics
- Tecnoroller NG assistance column with separately controllable auxiliary arms
- Mounting column in "oversized" design (140 x 140 mm)
- Internal clamping for steel rims without removal of the plastic protection
- Self-centering four-jaw chuck
- Adjustable tyre paste holder
- Automatic wheel release vertical and horizontal

Scope of delivery:

- MS 650 S V1
- Assistant column Tecnoroller NG
- Plastic protection for mounting head
- Plastic protection for bead breaker
- Bead hold-down plate
- Position marker for horizontal arm

Color: RAL7040

Passenger car tyre changer MS 650 S V6 WDK

The new S class of tyre mounting: strength, robustness and stability | Clamping range 12 - 28" | incl. assistance column Tecnoroller NG and soft start | without Tyre Leverless System

Article number: 1 694 201 261



- Together with the assistance column and soft start, full control over the assembly and disassembly procedure: For the protection of tyre, rim and tyre pressure monitoring system.

The NEW "S" concept:

- Robust mechanism with welded bead breaker
- Extended working area between tyre and mounting head
- Space saving: 50 mm smaller than comparable machines
- Service-friendly: removable pedal system for easy maintenance
- Flexibly upgradeable with a wheel lift for even better ergonomics
- Tecnoroller NG assistance column with separately controllable auxiliary arms
- Ergo Control bead breaker - without pedal, only fine and powerful controllable by hand, recoilless
- Mounting column in "oversized" design (140 x 140 mm)
- Internal clamping for steel rims without removal of the plastic protection
- Self-centering four-jaw chuck
- Adjustable tyre paste holder
- Automatic wheel release vertical and horizontal

Scope of delivery:

- MS 650 S V6 WDK
- Assistant column Tecnoroller NG
- Ergo Control bead breaker
- Plastic protection for mounting head
- Plastic protection for bead breaker
- Bead hold-down plate
- Position marker for horizontal arm

Passenger car tyre changer MS 650 S V6 IT

The new S class of tyre mounting: strength, robustness and stability | Clamping range 12 - 28" | incl. assistance column Tecnoroller NG | without Tyre Leverless System

Article number: 1 694 201 258



- Take full control over the assembly and disassembly procedure: For the protection of tyre, rim and tyre pressure monitoring system.

The NEW "S" concept:

- Robust mechanism with welded bead breaker
- Extended working area between tyre and mounting head
- Space saving: 50 mm smaller than comparable machines
- Service-friendly: removable pedal system for easy maintenance
- Flexibly upgradeable with a wheel lift for even better ergonomics
- Tecnoroller NG assistance column with separately controllable auxiliary arms
- Ergo Control bead breaker - without pedal, only fine and powerful controllable by hand, recoil-less
- Mounting column in "oversized" design (140 x 140 mm)
- Internal clamping for steel rims without removal of the plastic protection
- Self-centering four-jaw chuck
- Adjustable tyre paste holder
- Automatic wheel release vertical and horizontal

Scope of delivery:

- MS 650 S V6 IT
- Assistant column Tecnoroller NG
- Ergo Control bead breaker
- Plastic protection for mounting head
- Plastic protection for bead breaker
- Bead hold-down plate
- Position marker for horizontal arm
- Integrated Inflation Technology (IT)

Basic Service



Passenger car tyre changer Start Line TF 311 | 400/3/50 | RAL7016
Article number: 1 694 400 024



Passenger car tyre changer Start Line TF 311 | 230/1/50 | RAL7016
Article number: 1 694 400 025



Passenger car tyre changer Start Line TF 311 | 230/1/60 | RAL7016
Article number: 1 694 400 027



Passenger car tyre changer Start Line TF 311 | 400/3/50 | RAL5015
Article number: 1 694 200 947



Passenger car tyre changer MS 530 S | RAL5015
Article number: 1 694 201 113



Passenger car tyre changer MS 530 S | RAL7040
Article number: 1 694 201 114



Passenger car tyre changer MS 530 S IT | RAL5015
Article number: 1 694 201 115



Passenger car tyre changer MS 530 S IT | RAL7040
Article number: 1 694 201 116



Passenger car tyre changer MS 530 S V1 WDK
Article number: 1 694 201 118

High Volume



Passenger car tyre changer MS 630 S V6 WDK
Article number: 1 694 201 235



Passenger car tyre changer MS 630 S V6 230/1/50 | with inverter
Article number: 1 694 201 234



Passenger car tyre changer MS 630 S 400/3/50
Article number: 1 694 201 158



Passenger car tyre changer MS 630 S V1 400/3/50 | incl. assistance column Tecnoroller NG
Article number: 1 694 201 160



Passenger car tyre changer MS 630 S V6 400/3/50 | Two speeds
Article number: 1 694 201 162



Passenger car tyre changer MS 630 S 400/3/50 | RAL7040
Article number: 1 694 201 217



Passenger car tyre changer MS 630 S V1 400/3/50 | incl. assistance column Tecnoroller NG | RAL7040
Article number: 1 694 201 219



Passenger car tyre changer MS 630 S V6 400/3/50 | Two speeds | RAL7040
Article number: 1 694 201 221



Passenger car tyre changer MS 630 S V6 | WDK | 400/3/50 | RAL7040
Article number: 1 694 201 222



Passenger car tyre changer MS 650 S V1 | RAL7040 | WDK
Article number: 1 694 201 254



Passenger car tyre changer MS 650 S V6 WDK

Article number: 1 694 201 261



Passenger car tyre changer MS 650 S V6 IT

Article number: 1 694 201 258

Premium Service



Passenger car tyre changer MS 670 S V6

Article number: 1 694 201 295



Passenger car tyre changer MS 670 S V8

Article number: 1 694 201 271



Passenger car tyre changer MS 670 S V8 IT

Article number: 1 694 201 272



Passenger car tyre changer MS 800

Article number: 1 694 201 466



Passenger car tyre changer MS 800 | WDK

Article number: 1 694 201 456

Truck



Truck tyre changer MS 70

Article number: 1 694 200 070



Truck tyre changer MS 75

Article number: 1 694 200 074



Truck tyre changer MS 78

Article number: 1 694 200 079



Truck tyre changer MS 78 RC

Article number: 1 694 200 081



Truck tyre changer MS 80

Article number: 1 694 200 083



Inflation Cage | for truck tyres

Article number: 1 694 302 032

Tyre diagnosis system Easy Tread | Above ground

Automatic tyre tread measurement system with crossing speed up to 8 km/h | Easy Tread for above ground installation

Article number: 1 691 200 000

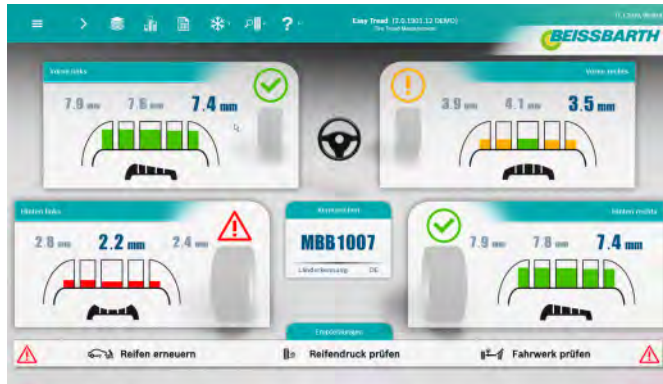

The tyres are the only contact points between a vehicle and the road. The quality of this bonds decides how safely the vehicle can be accelerated and braked. Especially aquaplaning can only be avoided by sufficient tread depth. This is why checking tread wear is a mandatory item of all statutory safety inspection. At the same time, uneven tread wear is a clear indication for a workshop that a wheel alignment should be considered - and that a wheel alignment check should be proposed to the customer.

- The Easy Tread needs only few seconds to calculate the tyre's tread depths of a vehicle
- Clear display of tyre tread depth and wear information, within short time
- Recommended action are displayed (for the vehicle and/or the tyre)
- Crossing speed up to 8 km/h
- Can be integrated above ground in the workshop
- High precision thanks to the larger wheel contact area
- Browser-based measurement results on smart TV, PC or tablet computer
- No PC needed (can be however used to manage Customer-data, measuring data and statistics)
- Interface to connect the device in a customer owner system, where the data can be transferred for further processing (option)
- No moving parts (low maintenance)
- Measures in both directions of vehicle crossing over system
- Quality from Germany

Scope of delivery:

- Easy Tread modules incl. Drive-on ramps for above ground installation (measurement modules, drive-on ramps, LAN cables, main switch box, glass cleaner

The ANPR camera to capture the license plates for every

crossing needs to be ordered separately.

Tyre diagnosis system Easy Tread | Inground

Automatic tyre tread measurement system with crossing speed up to 8 km/h | Easy Tread for inground installation

Article number: 1 691 200 002

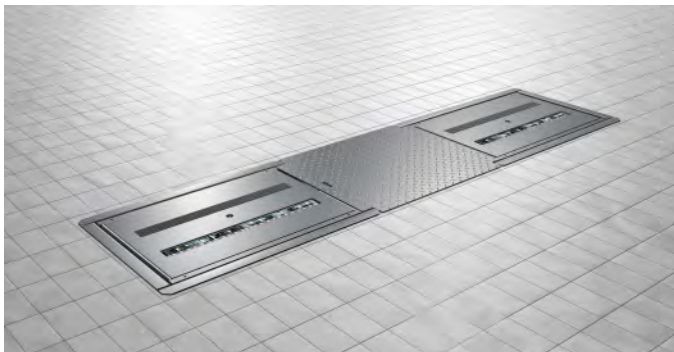

The tyres are the only contact points between a vehicle and the road. The quality of this bonds decides how safely the vehicle can be accelerated and braked. Especially aquaplaning can only be avoided by sufficient tread depth. This is why checking tread wear is a mandatory item of all statutory safety inspection. At the same time, uneven tread wear is a clear indication for a workshop that a wheel alignment should be considered - and that a wheel alignment check should be proposed to the customer.

- The Easy Tread needs only few seconds to calculate the tyre's tread depths of a vehicle
- Clear display of tyre tread depth and wear information, within short time
- Recommended action are displayed (for the vehicle and/or the tyre)
- Crossing speed up to 8 km/h
- Can be integrated inground in the workshop
- High precision thanks to the larger wheel contact area.
- Browser-based measurement results on smart TV, PC or tablet computer
- No PC needed (can be however used to manage Customer-data, measuring data and statistics)
- Interface to connect the device in a customer owner system, where the data can be transferred for further processing (option)
- No moving parts (low maintenance)
- Quality from Germany

Scope of delivery:

- Easy Tread modules for inground installation (measurement modules, LAN cables, main switch box, glass cleaner)

The ANPR camera to capture the license plates for every crossing needs to be ordered separately.

For inground installation an installation frame is required as well as a center cover, depending on whether a ANPR camera is used or not.

Easy Tread

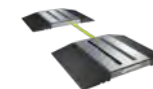

Tyre diagnosis system Easy Tread | Above ground

Article number: 1 691 200 000



Tyre diagnosis system Easy Tread | Inground

Article number: 1 691 200 002



КАТАЛОГ ШИНОМОНТАЖНЫХ СТАНКОВ

Архангельск (8182)63-90-72
Астана (7172)727-132
Астрахань (8512)99-46-04
Барнаул (3852)73-04-60
Белгород (4722)40-23-64
Брянск (4832)59-03-52
Владивосток (423)249-28-31
Волгоград (844)278-03-48
Вологда (8172)26-41-59
Воронеж (473)204-51-73
Екатеринбург (343)384-55-89
Иваново (4932)77-34-06

Ижевск (3412)26-03-58
Иркутск (395)279-98-46
Казань (843)206-01-48
Калининград (4012)72-03-81
Калуга (4842)92-23-67
Кемерово (3842)65-04-62
Киров (8332)68-02-04
Краснодар (861)203-40-90
Красноярск (391)204-63-61
Курск (4712)77-13-04
Липецк (4742)52-20-81

Киргизия (996)312-96-26-47

Магнитогорск (3519)55-03-13
Москва (495)268-04-70
Мурманск (8152)59-64-93
Набережные Челны (8552)20-53-41
Нижний Новгород (831)429-08-12
Новокузнецк (3843)20-46-81
Новосибирск (383)227-86-73
Омск (3812)21-46-40
Орел (4862)44-53-42
Оренбург (3532)37-68-04
Пенза (8412)22-31-16

Россия (495)268-04-70

Пермь (342)205-81-47
Ростов-на-Дону (863)308-18-15
Рязань (4912)46-61-64
Самара (846)206-03-16
Санкт-Петербург (812)309-46-40
Саратов (845)249-38-78
Севастополь (8692)22-31-93
Симферополь (3652)67-13-56
Смоленск (4812)29-41-54
Сочи (862)225-72-31
Ставрополь (8652)20-65-13

Казахстан (772)734-952-31

Сургут (3462)77-98-35
Тверь (4822)63-31-35
Томск (3822)98-41-53
Тула (4872)74-02-29
Тюмень (3452)66-21-18
Ульяновск (8422)24-23-59
Уфа (347)229-48-12
Хабаровск (4212)92-98-04
Челябинск (351)202-03-61
Череповец (8202)49-02-64
Ярославль (4852)69-52-93

<https://beissbarth.nt-rt.ru> || bhp@nt-rt.ru